

# Savage Pistols: The Birth of the .45 and the Savage Automatic Pistols

Bailey Brower, Jr.

*Editor's Note: Bailey Brower spoke to American Society of Arms Collectors from his knowledge, which led to Chapter 2 of his Savage book. Bailey provides the history of the .45 caliber military test pistol and pictures he shared at the presentation.*

As discussed in the previous chapter, the Savage Arms Company's automatic pistol design did not originate in the company's Utica, New York, factory—or even in the gifted mind of company founder, Arthur W. Savage. Instead, the concept came from the Philadelphia drawing board of Elbert Hamilton Searle, financed by William Condit. (Figure 1) Searle had been working for several years to develop a self-loading handgun, but it was only after he had secured the financial and managerial support of Condit that he started to bring his ideas to fruition in the early years of the twentieth century.

It is important to consider the status of the semiautomatic pistol in the United States at this time. The concept had been embraced in Europe starting in the late 1880s and by the turn of the century gun owners, especially those in the military, were enthusiastically carrying semiautomatic Mausers, Mannlichers, Lugers, and Brownings. In the United States, things were quite different. At the start of the twentieth century—not surprisingly—Colt was only U.S. manufacturer working with semiautomatic designs. Its first semiautomatic, the .38 caliber Model



Figure 1. Portrait of Arthur W. Savage (date unknown).

1900, was a John Browning design, but because of its long barrel, unbalanced slide, and lack of positive safeties (such as a grip or magazine safety) it was not particularly successful.

Despite its drawbacks, Colt sold 3,300 Model 1900s on the civilian market and supplied 250 pistols to the U.S. Navy and another 300 to the U.S. Army for testing. Colt then followed up with the redesigned and somewhat better balanced Model 1902, which



was chambered for the .38 ACP cartridge. Colt produced a military version of the pistol—equipped with a lanyard ring—that was also tested by the U.S. military, but the vast majority of the 18,000 Model 1902s sold through 1929 went to the commercial market.

Meanwhile, Colt Single Action Army revolvers remained the standard military sidearm, though the .38 caliber version then in vogue was deemed to have inadequate stopping power—a lesson learned the hard way during violent conflict with Filipino guerrillas. The military wanted a new .45 caliber sidearm. As a stopgap measure, in 1902 the army started using the new Colt Double Action .45 revolvers, but the U.S. military was seriously looking at semiautomatic designs.

In addition to the military market, Colt was just as interested in supplying automatic pistols to civilian consumers with a growing interest in this style of gun, especially when they could be carried easily. Colt responded with the Model 1903, its first pocket pistol design, and one that utilized an exposed hammer. This pistol stayed in production until 1929, with Colt selling a modest 26,000 guns over its production life. A more important product released the same year was the Model 1903 Hammerless. This .32 caliber pocket pistol was another work of John Browning genius and it stayed in production until 1945—in total 200,000 went to military customers and more than a half million were sold to civilians. In 1908 Colt followed up with two more new models: John Browning's very compact and

very popular Model 1908 Hammerless .25 caliber pistol, which stayed in production until 1941 and tallied sales in excess of 400,000; and the Model 1908 Hammerless .380 (a modified version of the Colt .32 pistol), which tallied sales of 138,000 to the civilian market over its production run, as well as military sales.

### THE SEARLE PISTOLS

Thus it was two emerging markets—military and civilian—that Elbert Searle and William Condit had in mind as they worked in Philadelphia starting in 1903. A small design shop might have been at a severe disadvantage competing against Colt, but they also believed that the right design might catch the eye of the Connecticut arms giant, or even an upstart company seeking an opportunity to compete on more equal footing with Colt. Ultimately it was an upstart—Savage—that embraced an Elbert Searle pistol design, though this process was not exactly simple or direct.

Confusing the history behind the development of the Savage automatic pistol is the fact that on November 21, 1905—the date carried on the slide legend of every automatic pistol Savage ever manufactured—Searle was granted patents for two very different pistol designs. Searle's first patent application was made in late 1903, not long after he started working with Condit. Externally, the proposed pistol looks something like the Colt Woodsman, the popular John Browning-designed .22 caliber target model that reached the market in 1915. This first Searle design, which was in .38 caliber, bears little resemblance to later Savage pistols. It featured a concealed hammer, a flat mainspring, a fixed barrel, and a short, moveable breechblock. Nonetheless, it also has three significant traits that were retained for future designs: no screws were used in its assembly except to hold the grips in place; the magazine featured a staggered, box-type design; and the magazine release lever was on the front of the grip.

Searle's first patent application had barely been submitted when he made an abrupt departure from his original line of development. His initial pistol design had been fairly conventional, and maybe he sensed that he had to produce something more unique to get a manufacturer's attention—or maybe he simply came up with some unique ideas. Regardless of the motivation, by October 1, 1904, he filed an application for a pistol that was dramatically different than any other being manufactured at that time. When granted the following year, the patent for this pistol design was No. 804,985. (Figure 2)

Externally, this gun exhibited some of what became recognizable characteristics of Savage pistols, but it wasn't that much different from contemporary semiautomatic designs. The real departure from the standards of the day could be found on the inside. The most significant feature was a rotating

barrel—part of what Searle described somewhat inaccurately as a locked-breech system. In reality, the gun operated under the principle of delayed blowback. A lug on the barrel acted as a positive locking mechanism, preventing the slide from opening prematurely. On firing, the barrel rotated about 5 degrees, moving the lug to a position that allowed the slide to open—but the point of Searle's design was to prevent this rotation from happening immediately. This was accomplished thanks to the counter-rotational force of a fired bullet traveling through the barrel. In interacting with the rifling the bullet momentarily counteracted the barrel rotation, which in turn delayed the slide opening until after the bullet departed the barrel . . . in theory. In reality, the slide opened momentarily *before* the bullet exited the gun, but the design was still effective in preventing the breech from opening prematurely.

The pistol had a variety of other attractive features. A true single action, its external, knurled cocking lever was con-

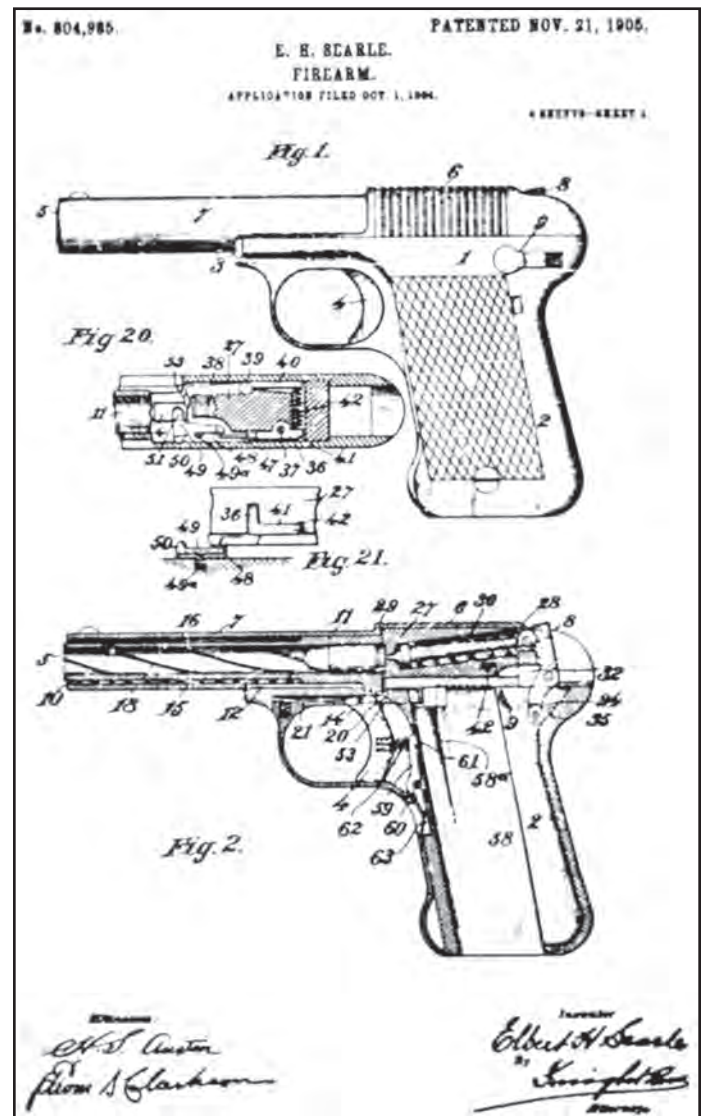

Figure 2. First page of Elbert Searle's 1905 patent (No. 804,985, applied for October 1, 1904, and granted November 21, 1905). This is the basic design that led to the Savage .45 caliber and Model 1907 semi-automatic pistols and is the patent referred to on the slide on most pistols.

nected directly to the firing pin. The cocking lever and striking pin were part of the breechblock, which also contained the extractor and its spring. The magazine could be released fairly easily by pressing a lever on the front of the grip strap. Cartridges were double-stacked in the magazine to increase capacity—the first time this design appeared on any commercial pistol (though it was resurrected in the 1950s by the Smith & Wesson Model 39). This feature allowed the pistol to hold nine cartridges (eight in the magazine plus one in the chamber), a higher capacity than competing Colt or Luger models. The pistol dispensed with fragile flat springs (not a single one was employed) and made generous use of coil springs throughout, including a large counter-recoil spring wrapped around the barrel. Perhaps the best feature of the design was the fact that it employed relatively few parts and was very simple to disassemble and assemble. No tools were required and this initial design used screws only to hold the grips in place—and eventually these were eliminated (at least until the Model 1917 was developed).

#### ENTER THE SAVAGE ARMS COMPANY

Though the exact circumstances of how Savage Arms Company and Elbert Searle came together are unknown, it appears that William Condit approached Savage in late 1904 after the patent was filed for Searle's second pistol design. Both sides realized the promise of the design for military applications. The relationship blossomed in earnest in February 1906 when the U.S. Army sent out notice that it wanted .45 caliber automatic pistols for a test in September. Apparently Searle started working at Savage's Utica plant, furiously trying to refine his design and have a prototype manufactured in time for the fall trials. He looked destined to fail until the Army postponed the trials until January 15 of the following year, giving him time to finish the project.

An eight-shot prototype pistol, which featured several improvements over Searle's original design was completed in time for the January 1907 trials. The modifications included a new slide lock, ejector, and action. There was also an ingenious lanyard loop (a nod to its military goal) that could be folded up in to the grip when not in use. Searle filed a patent application for these changes on April 25, 1907; patent No. 936,369 was granted on October 12, 1909. This design, without a lanyard ring, is what

became commercially identified as the Model 1907 pocket pistol when it was manufactured in .32 caliber. (Figures 3 and 4)

Meanwhile, the Ordnance Department put the Savage prototype through its paces, firing 913 rounds through the weapon. The pistol from the upstart arms manufacturer was facing some heady competition. Colt had submitted a .45 automatic (designed by John Browning) for the trials, along with a revolver. Smith & Wesson had a revolver in the field. Deutsche Waffen und Munitions had provided a .45 caliber Luger. Bergmann was the other German Manufacturer represented. Great Britain's Webley & Scott had entered the fray with its Webley-Fosbery automatic revolver. Grant Hammond also entered an interesting pistol in the trials that never made it to the firing tests. Their design was disqualified because it called for the magazine to automatically eject

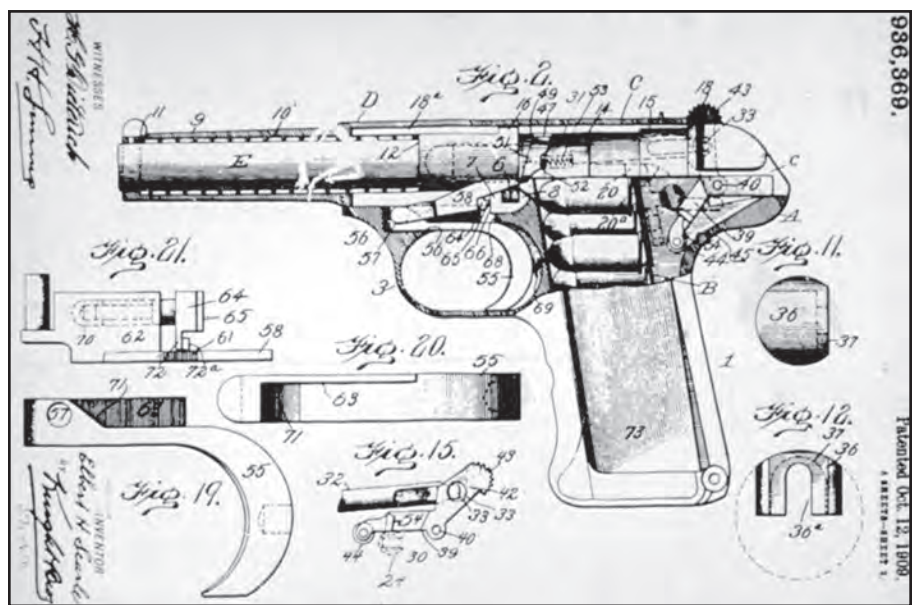
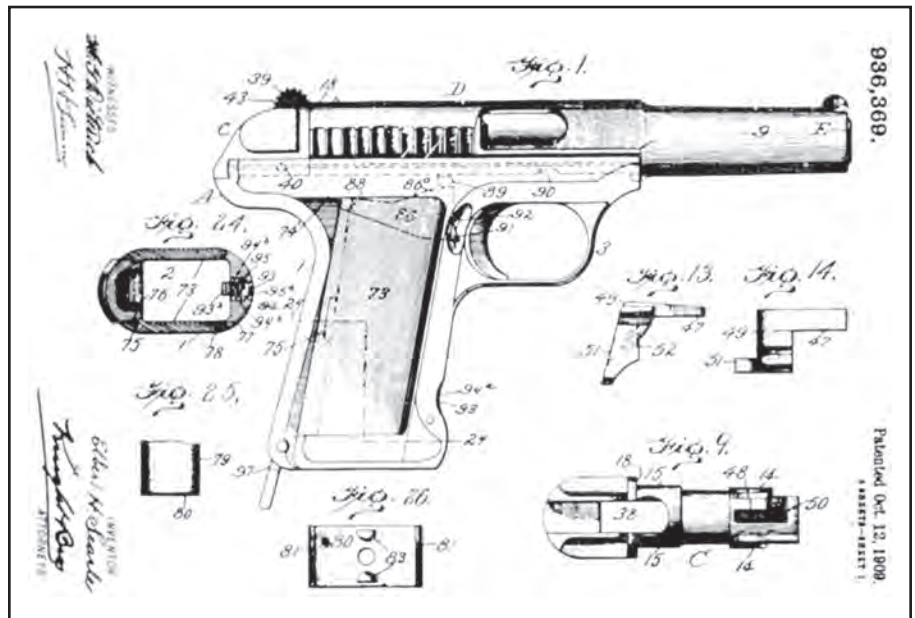

Figures 3 and 4. Two pages from Elbert Searle's patent (No. 936,369, applied for April 25th, 1907, and granted October 12, 1909) for improvements to his original pistol design that were incorporated as a result of the January 1907 military trials.

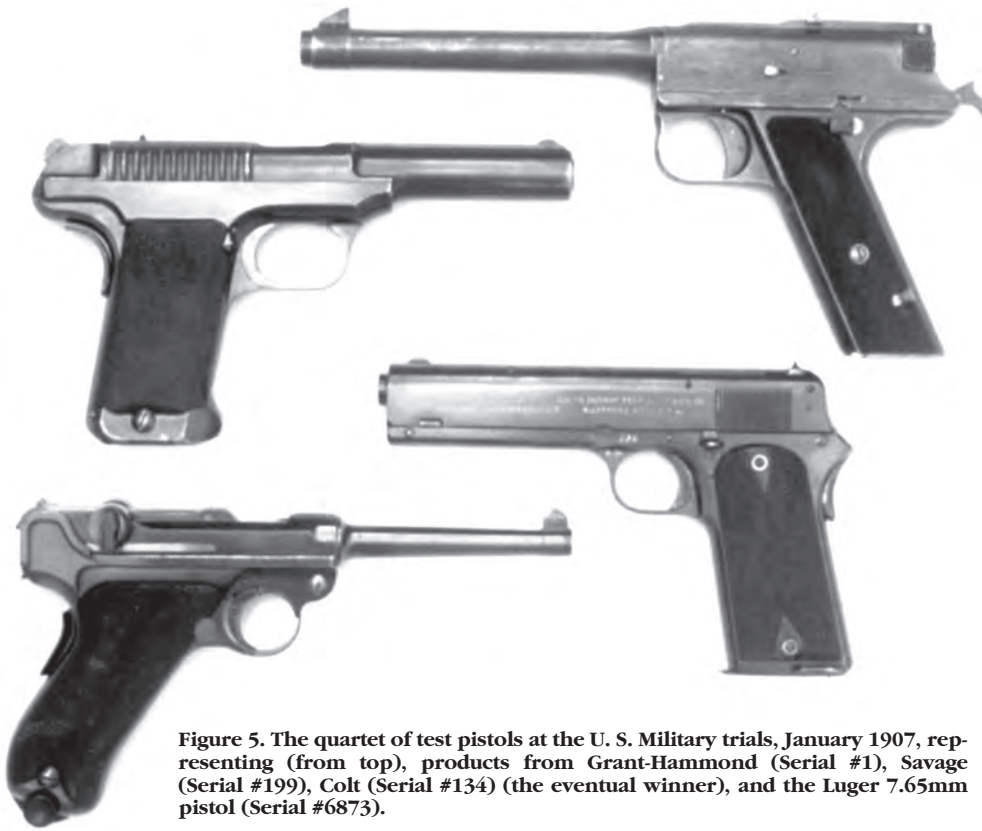

Figure 5. The quartet of test pistols at the U. S. Military trials, January 1907, representing (from top), products from Grant-Hammond (Serial #1), Savage (Serial #199), Colt (Serial #134) (the eventual winner), and the Luger 7.65mm pistol (Serial #6873).

when the cartridges were spent. Though rejected by the military, the Grant Hammond design later became the basis for the hugely successful High Standard .22 caliber automatic pistol. (Figure 5)

In the end the Army decided that only the Colt and the Savage entries demanded further testing. The test report praised the Savage for “. . . the number of cartridges (eight) held by the magazine . . . the way the pistol lies in the hand, the expulsion of the magazine by the pistol hand and the ease with which the mechanism may be retracted.” The report noted that the Savage won both the velocity test (at 819 feet per second) and the dust test (in which it was blasted with fine

sand before firing). In addition, the test board favored the fact that the Savage avoided flat springs and had only 34 parts—nine fewer than the Colt—that were easy to assemble and disassemble. (Figures 6 and 7)

Despite the glowing report, the Army wanted some changes made to the pistol before testing it again. They requested that Savage eliminate the metal grips in favor of wood, move the front sight back somewhat from the edge of the muzzle, relocate the cartridge ejector port to the side of the slide, and add a grip safety. The biggest problem was one that was more difficult to remedy, and something that ultimately tipped the scales in Colt’s favor: Some of test-firing personnel thought the Savage experienced too much recoil. (Figures 8, 9 and 10)

It is interesting to note that after the test, both Luger and Savage raised concerns regarding the quality control of the cartridges used during the test. Both companies felt that inconsistent loads created problems that reflected unfairly on their test pistols and could have been avoided with higher quality ammunition.

#### THE COMPETITION CONTINUES

The test results represented a tremendous coup for Savage, but financial problems initially prevented any celebrations in Utica. In May 1907 the Army placed an order for 200 redesigned test pistols from both of the top two finishers. Colt responded that it would supply the requested guns



Figures 6 and 7. Left and right views of the original Savage Model 1907-10, .45 caliber test pistol, Serial #1, that was used for the prototype for the redesigned Model 1910 test pistols.



**Figure 8.** Left view (plus magazine) of the Colt, .45 caliber pistol (one of 200), supplied for the January 1907 military trials, the predecessor of the famous Colt Model 1911 automatic service pistol. The pistol is Serial #134.



**Figure 9.** Left side view of the 7.65mm caliber Luger pistol, (1 of 1,000), provided by Luger for the testing by the U. S. military prior to the final test trials. The Luger is Serial #6873.



**Figure 10.** Left view of .45 caliber pistol (Serial #1), supplied by Grant Hammond for the January 1907 trials. This design was rejected because the magazine automatically ejected when the cartridges were spent. It later became the basis for the successful High Standard .22 caliber pistol.

in less than one year at a price of \$25 each. Savage did not have the resources to match such an aggressive project. Remarkably, the company declined the offer. It looked as if the competition was over.

With Savage declining the opportunity to proceed in the trials, DWM—whose 7.65 mm Luger (part of an order of 1,000 guns previously purchased by the U.S. Army for field testing) finished third in the first test—tentatively offered to replace Savage in the next phase of the trials. The German company soon changed its mind, possibly after analyzing the cost of the extensive tooling that would be necessary to manufacture .45-caliber Luger and also because of cartridge issues related to the larger caliber. It has also been suggested that Georg Luger withdrew from the trials because he thought his company was being used as a “straw man” in a competition favoring U.S. manufacturers.

Regardless of the reasons for the Luger withdrawal, this development gave Savage a second chance, and the company reconsidered after finding the financing it needed to push forward in the competition. In August 1907 Savage agreed to supply the 200 test .45s at a cost of \$65 each. In part, Savage may have said “yes” because its management saw the possibility of recouping its tooling investment by concurrently developing a line of .32 caliber commercial pistols.

There are some who believe that the reason military was willing to pay Savage \$65 per pistol compared to Colt’s \$12.50 was to create the “fiction” that a true competition had been held in choosing what most thought would inevitably be a Colt pistol. Because neither Smith & Wesson nor Remington had an automatic pistol in production—or even in design—foreign manufacturers were the only companies with the know-how and plant capacity to build an automatic pistol for the U.S. military, not a desirable outcome. (Similar suggestions have been made regarding the more recent competition between Beretta and Smith & Wesson.) Savage as Colt’s “token” American competitor surprised everyone by performing so well at the initial tests. Some further speculate that the trials were strung out for so long to ensure that Colt had the time to develop a superior product to Savage and thus earn the final contract.

Work on the pistols—known as the Savage .45 caliber Model 1907 Military Contract—officially started when a contract was signed on October 21, 1907, but there were problems throughout the production run and things did not progress smoothly or quickly. Some of the delays may have been the result of Savage committing to producing a commercial .32 caliber version of the design (the Model 1907) while also working on the military contract. Meanwhile, Colt was making great progress on its commitment to the Army and the Connecticut manufacturer delivered its 200 test pistols to the armory in Springfield, Massachusetts, in

March 1908. Savage completed its first test pistol about six weeks later—perhaps not coincidentally about when the first Model 1907 .32 was completed—and did not get production in full swing until August.

Savage finally delivered its test pistols to Springfield in November 1908. Only 195 guns completed the trip; no one knows where the five “lost” Savages ended up and their serial numbers are unknown. In mid-December, Savage supplied replacements for the five missing pistols. After inspection and test firing at the armory, the pistols were deemed in “unsatisfactory” condition and promptly returned to Utica for repairs. The primary reason for rejection was the fact that the pistols lacked “Fire” and “Safe” markings on frame adjacent to the safety lever, making them very dangerous in the hands of soldiers who were probably unfamiliar with handling automatic pistols. Maybe Savage believed that a “cocked” hammer was enough indication of a ready-to-fire pistol, but obviously no one had any idea if the trigger could be pulled or was “locked out” by the safety.

This setback was followed by another when only 128 pistols successfully made the return trip to Utica. The fate of the seventy-two pistols, which may have been stolen or simply lost, has never been determined. In addition to stamping “fire” and “safe” on the existing pistols, Savage manufactured replacements for all the “lost” pistols, serializing these beyond the numbers assigned to the original 200 Model 1907 test pistols. These replacements explain why 288 has become the accepted total for the number of pistols (excepting the original prototype) that Savage manufactured for the military tests.

On March 16, 1909, a full complement of 200 Savages finally arrived in Springfield. Upon being deemed acceptable, the test Colts and Savages were assigned to less-than-enthusiastic U.S. Army cavalry units for field testing—these men were fond of their revolvers and not in a hurry to get rid of them. Sixty-four Savages were issued to each of the following: Troop I, 3<sup>rd</sup> Cavalry, Fort Wingate, New Mexico; Troop G, 6<sup>th</sup> Cavalry, Fort Des Moines, Iowa; Troop G, 11<sup>th</sup> Cavalry, Fort Oglethorpe, Georgia. In addition, two pistols were sent to the School of Musketry at The Presidio in San Francisco, and one remained with the Chief of Ordnance in Washington, D.C. The specific serial numbers issued to each troop are unknown, though it appears the School of Musketry received Nos. 2 and 7. The pistols were also sent out with custom-fitted U.S. Cavalry leather flap holsters that were made at Rock Island Arsenal—a very few of which are still known to exist.

The field tests generally did not go well, but that can probably be attributed more to the skeptical attitude of the cavalry troops rather than the pistol’s performance. Even in the face of this resistance, Savage remained committed to winning what could be a hugely lucrative contract and continued

to refine elements of the design. In February 1910 Savage notified the Chief of Ordnance that a new .45 was now available featuring a number of major improvements: a heavier slide; thick, smooth walnut grips; a new magazine; and a smaller rear sight and ejector. The Savage factory modified nine of the Model 1907 .45 caliber test pistols to the new design—serial numbers 1, 5, 14, 15, 27, 90, 114, 166, and 170—a variation designated the Model 1910 .45 caliber.

The original Model 1907 .45 caliber serial number 1 had been retained by the factory and was used as the prototype for the redesigned Model 1910 test pistols. This pistol was fitted with the new, heavier slide and a number of other modifications were made, not all of which were incorporated into the final eight Model 1910 test pistols. Gary Paul Johnston, in an article written for the *American Rifleman*, described the modification of the Model 1907 .45 caliber serial number 1 into the Model 1910 prototype, as well as the one-of-a-kind pistol’s subsequent “rediscovery.” Serial number 1 had actually been retained by the Savage factory until sometime in the late 1960s when it, along with a number of other “front office display” guns, were sold by the company.

The Model 1910 was a better product than the Model 1907, but Savage was facing the harsh reality of competing against a larger company with greater resources at its disposal. Colt had also been working to improve its semiautomatic .45 and it had made great strides. When the Army tested the two contenders again at Springfield November 10–18, 1910, Colt’s pistol had evolved very near to what most shooters would recognize as the venerable Model 1911. After putting at least 1,000 rounds through each of the pistols, the board was still unwilling to make a final decision. Noting that neither pistol was yet ready for adoption, the board nonetheless remarked that the Colt was “much the more satisfactory.” The Savage proved better in penetration tests, and its easily disassembled thirty-four parts and larger magazine capacity were still huge selling points, but the Colt registered a better average velocity and it was clearly superior in both accuracy and speed of fire.

#### THE FINAL ROUND

Savage had one last opportunity to win this competition, a final “shoot off” in March 1911, and the company answered with yet another upgrade to the .45 caliber pistol design, one now referred to as the Model 1911 .45 caliber. Among the changes made for this final test pistol were a grip safety running the length of the backstrap, an integral front sight milled out of the slide, a redesigned cocking lever, and a new magazine that corrected problems but abandoned the double-stacked configuration, resulting in a smaller capacity. In addition, the smooth walnut grips gave way to a checkered version and the slide release had migrated to the left side of the frame

just above the grips and increased in size. The slide release had previously been located in front of the trigger on the right side of the frame, which made it very difficult to operate. With the new location, the thumb of a right-handed shooter could easily release the slide. Four pistols, serial numbered 1 to 4, were manufactured to the 1911 design. (Figure 11)

March 15, 1911, was the chosen day for the final competition at the Springfield Armory, an endurance test of 6,000 rounds. The event drew a crowd of observers that included the presidents of both Colt and Savage, along with the inventors of both pistols, John Browning and Elbert Searle. In retrospect, the competition wasn't very realistic—few military pistols see 6,000 rounds in their service lives, let alone in one day—but in the end the marathon shoot-off helped the Army



**Figure 11. Left view of Savage .45 caliber pistol, Model 1911—serial #3,—only 4 were made for the final run-off test. This Savage has mixed parts number 3 & 4. Presumption is that this is the actual Test pistol as it is heavily worn inside. Improvements: Full length grip safety, a heavier hammer, recessed front sight, and hold open lever on the left side of frame.**

make its decision. Apparently both pistols performed quite well through the first 1,000 rounds, and the reworked Savage even delivered faster average velocities than its Colt competitor, 849 feet per second versus 828 feet per second. Ultimately the Savage's heavy recoil started to take a toll on the gun's parts. By the end of the competition the Colt had performed without a hitch, while the Savage suffered through thirty-one malfunctions and had five parts break down during the test firing. The board's choice was simple and the Colt 1911 became the military's automatic pistol of choice and one of the most popular firearms ever designed.

In analyzing the performance of the two pistols under such a grueling test, Colt's experience manufacturing automatic pistols, along with its superior know-how in metallurgy and appropriately fitting steel parts, appears to have given the Connecticut gun manufacturer a clear advantage in creating a product that was able to withstand a thousand-round marathon. John Browning's design was less "tight" than the Savage, which like the Luger was made using extremely

close tolerances. It is likely that the wearing surfaces on the tight-fitting Savage parts, especially on being subjected to the heat and expansion caused by the test, likely experienced more abuse than the parts on the Colt pistols.

Despite the outcome, the Savage pistol gave an exceedingly good account of itself against a challenging competitor and its development opened the door for the company to manufacture commercial pistols.

At the end of the testing, Savage bought back 181 of the Model 1907 .45s for \$6.50 each, just 10 percent of the price (\$65) originally paid by the Army for the guns. Savage made these .45s available on the commercial market, repairing, refinishing, and shipping them out as orders came in. Because sales occurred over the course of several years, .45s were sold wearing at least three different finishes, depending upon what the factory was using for its commercial pistols at the time. Considering the hard service that these pistols went through during field-testing, it is likely that most were well worn upon returning to Utica. Accordingly, any .45-caliber pistol encountered today in 98-percent condition or better was likely refinished at some point in its history.

A modification that has caused confusion among collectors is the fact that .45s sold prior to World War I had most of their slide legend removed before finishing and shipping. On these pistols, only "CAL. 45" remains on the slide. After the war, .45s sold out of inventory were re-stamped with a new slide legend with the new name "Savage Arms Corp." before they were refinished (in the post-war matte blue) and shipped.

Sales continued at low levels into the 1920s, when a limited number of the .45s remained unsold in the warehouse. At that point, Savage made a deal with distributor Tryon & Company of Philadelphia, selling the remaining inventory for \$12.50 each. These pistols were refurbished with a somewhat unattractive (and probably inexpensive) dull matte finish before leaving the factory. No internal upgrades were made to these guns.

Several of the .45-caliber pistols survive in collectors' hands in these various incarnations, but there has been some debate over how many were originally manufactured. Some have claimed that as many as 500 were built, but there is absolutely no evidence to support this grossly inflated number. Savage production records list 288–290 serial numbers (thanks to the "lost" pistols from the test program), and this should be considered the most reliable tally of Savage .45 production.

Regardless of how many were originally built, any collector with a Savage .45 in his or her possession should

consider themselves lucky indeed: They own a verified military test pistol, they might have a prototype in their possession, and they possess one of the very few U.S.-manufactured, large-caliber automatic pistols sold until much later in time. This rare .45 also has a number of interesting features and modifications, including varied finishes, which were made to the pistols over a period of time. All of these factors make the Savage .45 a very valuable and collectible pistol, in addition to the fact that it is a significant piece of firearms history, a symbol of the little company that took on an arms giant—and nearly won. (Figures 12 and 13)

SUMMARY: THE EVOLUTION OF THE SAVAGE .45-CALIBER MODEL 1907

Despite the fact that relatively few were manufactured—roughly 290—the Savage .45-caliber Model 1907 semiautomatic pistol has an important place in the history of U.S. firearms *and* it has been identified in a remarkable variety of configurations. Currently, six variations of the .45s are known. The attributes displayed by each follow a logical progression of modifications made in the Savage factory as the guns progressed from U.S. Army test pistols to refurbished pieces

available for sale to the general public. The following summary follows, in brief, the evolution of the Savage .45 through its different incarnations. (Figure 14)

1. ORIGINAL MILITARY CONTRACT—200 PISTOLS

This is the order placed by the U.S. Army after the initial trials in January 1907. These pistols were *not* marked “Fire” and “Safe” by the safety lever. They carry the full slide legend “Manufactured by Savage Arms Co., Utica, N.Y. U.S.A Pat. Nov 21. 1905. CAL. 45” on the top of the rib. They were finished in the original “rust blue,” a beautiful but fragile finish. (Figures 15 and 16)

2. PISTOLS RETURNED FOR REPAIRS AND MODIFICATIONS—128 PISTOLS

These pistols have “Fire” and “Safe” stamped *through* the original blue finish. These letters appear white rather than blue. All 200 pistols originally ordered were returned for modifications, but 72 disappeared and have remained unaccounted for. They were replaced by the following group of newly manufactured .45s.

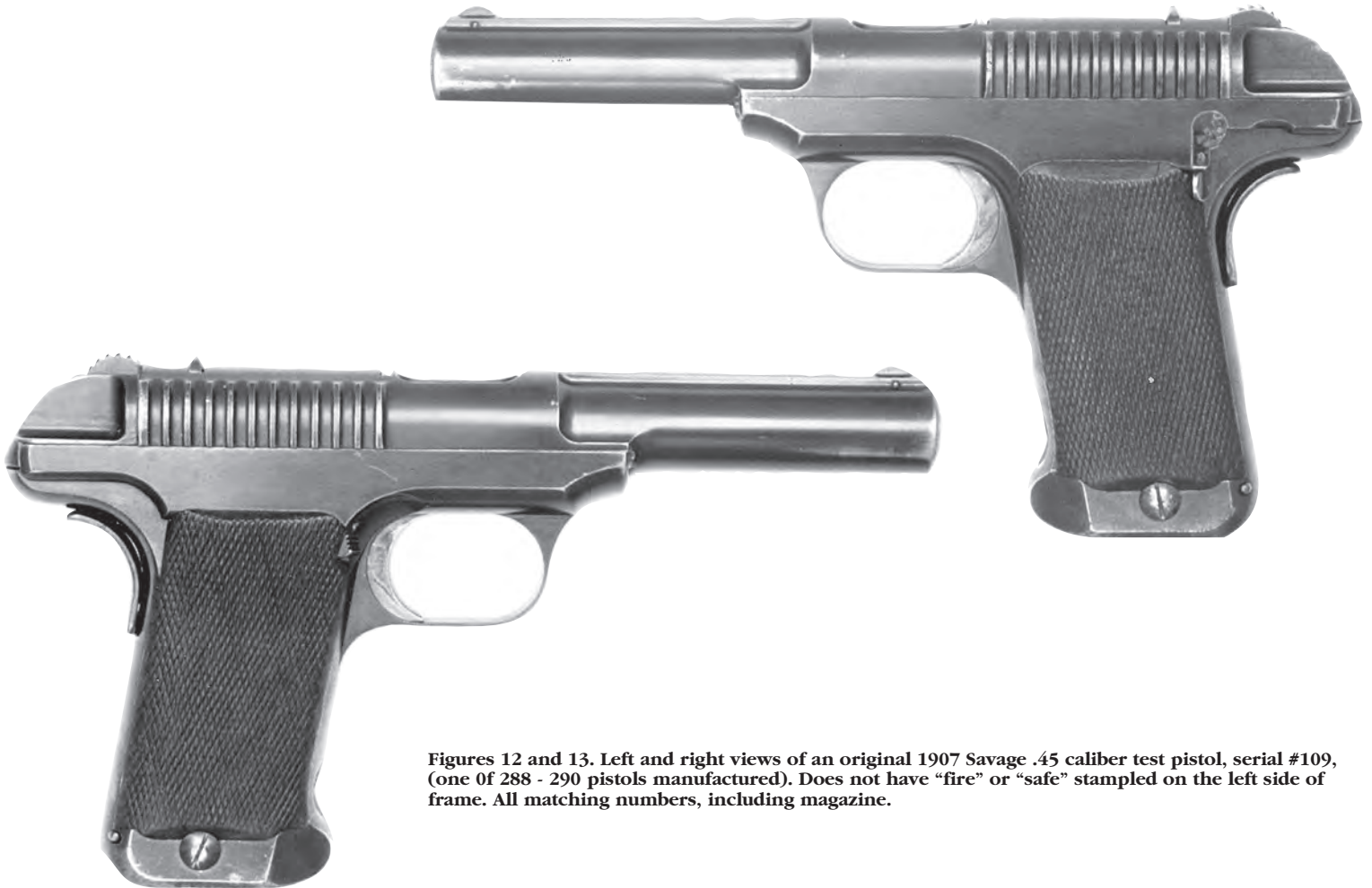

Figures 12 and 13. Left and right views of an original 1907 Savage .45 caliber test pistol, serial #109, (one of 288 - 290 pistols manufactured). Does not have “fire” or “safe” stamped on the left side of frame. All matching numbers, including magazine.



Figure 14. Left view of a well worn Savage 1907 .45 caliber test pistol, serial #208. Slide legend was removed by factory, leaving CAL 45. only. Lantard ring extends from butt.

### 3. MAKE-UP ORDER FOR LOST PISTOLS—72 PISTOLS

These pistols have “Fire” and “Safe” stamped on the frame *before* bluing. As with earlier guns, these were finished in the “rust blue.”

### 4. REFURBISHED GUNS SOLD PRIOR TO WWI— QUANTITY UNKNOWN

After the military testing was completed in 1911, Savage repurchased 181 of the test pistols and made them available for sale. As they were sold, and before being shipped, the pistols were refurbished and refinished. As a result, these pistols had all the information removed from the slide legend except for “CAL. 45.” They were refinished with the durable and bright “charcoal blue” that the factory was applying to Model 1907 pistols at the same time. Guns were sold in this configuration until about 1915. (Figure 17)



Figure 15.



Figure 16.

Figures 15 and 16. Two slightly different variations of the standard Savage .45 – caliber slide legends: Both have “Manufactured by Savage Arms Co., Utica, N.Y. U.S.A. Pat. Nov 21. 1905”. Slide #15, Savage serial #1 Model 1907–10, –with extended slide–, notes “CAL 45” while the second, serial #199– Model 1907, Slide #16, adds the period for “CAL.45”.

### 5. REFURBISHED GUNS SOLD AFTER WWI— QUANTITY UNKNOWN

These pistols were roll-stamped with a slide legend reading “Savage Arms Corp. Utica. N.Y. U.S.A.” on the left side of the slide below the rib. They also carried the caliber marking “CAL 45.” on the rib. They were refinished in the dull (or matte) blue-black found on Savage commercial pistols of the post-war era. (Figure 18)

### 6. TRYON & COMPANY GUNS—SMALL QUANTITY

Savage closed out its inventory of .45s in the 1920s by selling the remaining stock to this Philadelphia distributor. These pistols received only a cosmetic upgrade and were refinished with a less attractive dull matte finish that has been described by various sources as having a gray or green cast or even being “sandy.”

### SAVAGE PISTOL SERIAL NUMBERS

Because of the presence of replacement parts, or the occasional failure of the factory to stamp numbers on parts, serial numbers are not always where there are supposed to be. The following locations often reveal a serial number—but sometimes they don’t:

- The bottom of the breechblock. (This is the “accepted” serial number location when referring to a pistol’s serial number.)
- Inside the slide near the ejection port, stamped into the “groove” milled into the top of the slide for the barrel lug.



Figure 17. Factory legend on a refurbished Savage .45 caliber pistol sold prior to WWI. These pistols have all the slide legend lettering removed from the top of the slide except for “CAL.45”.



Figure 18. Factory legend on refurbished Savage .45 caliber pistol sold after WWI. These pistols were roll stamped on the left side of the slide, below the rib, with a slide legend reading “Savage Arms Corp., Utica, N.Y. U.S.A.”



Figure 19. Unique, one of a kind carved wood display to hold the nickel plated Savage .45 caliber pistol at an Exposition display. The walnut wood is of high quality rifle stock incised with great detail.



Figure 20. Replica Savage .45 caliber pistol holster (using the original Rock Island Armory blue prints), as used in the Calvary Test. note holster to be worn on the left side.

- The rear of the slide immediately under the “cut out” for the breechblock.
- The front of the frame, inside the rounded part. (Except for the Model 1910, where the serial number is stamped inside the rear of the frame under the breechblock “milling.”)
- The front of the magazine.

- The side of the ejector, which also serves as a sight.

Collectors should realize that as part of a test, an armorer would often take apart pistols and mix the parts. They often reassembled guns with any combination of parts—which were supposed to be interchangeable.

Few of the test pistols—which were given hard use by the cavalry units that field-tested them—can be found with “matching” serial numbers. Very few magazines have been found that correspond in serial number to the pistol in which they are found.

Having “mixed” serial numbers actually lends authenticity to Savage test pistols. When Savage repurchased the remaining test pistols, the company put the guns back into stock. When a customer wanted a Savage .45, the company pulled pistols from its inventory and reconditioned the guns before shipping them out. The company undoubtedly used parts from other pistols, furthering the spread of non-matching numbered parts in the .45s. (Figures 19 and 20)

#### Bibliography

Brower, Bailey, Jr. “Savage Automatic Pistols: A Study of Savage Pistol Grips, Showing Their Design Differences & Mechanical Evolution.” In *Man at Arms*, Volume 20, Number 4 (August 1998): 17-25.

Carr, James, R. *Savage Automatic Pistols*. Published by the author, 1967.

Malloy, John. “Early Rivals of the Model 1911 45 Automatic.” In *Gun Digest Treasury*, 7<sup>th</sup> Edition, 178-188. Northbrook, Ill.: DBI Books, 1994.

Meadows, Edward S. “Colt vs. Savage.” In *The Gun Report*, November 1991: 26-28.

Savage, R.D.A. “The Life of Arthur William Savage: A Draft Chronological Summary.” Unpublished manuscript, 2005.

Simmons, Donald M. “The Savage Pocket Automatic Pistol Model 1907.” In *The Gun Digest*, 35<sup>th</sup> Edition, 68-85. Northbrook, Ill.: DBI Books, 1981.

Stern, Daniel K. *10 Shots Quick: The Fascinating Story of the Savage Pocket Automatics*. San Jose, Calif.: Globe Printing Company, 1967.

Stern, Daniel K. “The Savage .45 Auto.” In *Shooting Times*, December 1967: 37-39.