

Debunking the Fluck Myth: Colt Legends Die Hard

Dick Salzer

Legends always die hard but this seems especially true of Colt legends. Take the example of those shiny-cylindrical Paterson carbines. For years it was accepted that they were created from partial Paterson parts, found at the factory by Albert Foster, a Colt employee. Foster allegedly had cylinders made and sold them to collectors in 1910 at \$75 each (Figure 1).

Herbert Houze, in his book *Colt Rifles and Muskets*, proves conclusively that examples were in existence in the 1890s, years before Foster went to work for Colt.¹ This piece is still referred to as the “Albert Foster Model” in auction catalogs.

A much more persistent legend is that of the “Fluck Dragoon.” Back in the 1940s, early percussion Colts, especially Walkers and Dragoons were one of the most popular collector specialties. I like to think of that era as the “Golden Age of Gun Collecting,” when discoveries could still be made in attics and gun shops, and when serious research on guns was just beginning.

The big names of the day—Serven, Metzgar, Bassett, and others—spent a lot of time discovering and documenting the Colt Dragoon series—a group of only about 19,000 guns produced over a 14-year period. They couldn’t resist categorizing within that short series as collectors love to do. These major categories are still used today. The Whitneyville Dragoons included the First, Second and Third models, and a basic Dragoon collection included these four types. There were sub-variations with special state markings and minor differences but these four categories were king.



Figure 1. Legend had it that the smooth cylinder Model 1839 Paterson Carbines were fabricated by Colt Superintendent Albert Foster in 1909 and sold to collectors. Herbert House dispelled this story in his book, *Colt Rifles And Muskets* by showing that specimens were in collections prior to 1900, years before Foster went to work for Colt. Auction catalogs still call them the “Albert Foster Patersons.”



Then along came John Fluck, who “discovered” a fifth major variation which he revealed in his now famous article of September 1956 entitled “*Colt’s Hartford Walker.*” Collectors were delighted as they now had a new challenge to pursue—a specimen of the “Fluck Dragoon.”¹

As we will see, there were some basic faults in the reasoning of those early collectors. While the Whitneyville series (only about 250 guns) could legitimately be argued to be a separate series, the other 18,600 +/- Dragoons were an evolutionary series incorporating improvements and economies over the period of their manufacture. Clearly Colt never thought of these guns as separate models.

Let me say here that this is not a criticism of Fluck or any of the early researchers. They worked with what they had and drew opinion from observation. Today we have infinitely more sources to draw upon (not the least of which are the works of those early researchers).

Having studied, documented and/or handled nearly 5% of the entire Dragoon production, I can confidently assure you of several things:

- The changes in design of Dragoon details are progressive and roughly correspond to ascending serial numbers.
- Colt had a penchant for

assuring continuity of his numbering. If a number had been missed, his workmen would fill that missing number with whatever gun carried the current features. This accounts for the existence of several guns with earlier numbers having features associated with later production. This fact is important to remember when we return to Fluck's contentions.

So exactly what did Fluck Say?

Fluck contended that 300 Dragoons in the serial number range from 2216 through 2515 were replacements, which Colt was forced to supply for Walkers that had failed in service, principally from cylinders exploding. He based this number on a letter from J. B. Colt to C. R. Johnson dated October 25, 1847 in which Colt states, "a small number, approximately 300, of our guns that were made in the Whitneyville Armory proved inoperative because of possible mishandling or prior damage . . ." ^b

He goes on to describe features which vary in minor details from *normal* Dragoons—things such as size and placement of frame markings and serial numbers, quantities of inspectors' marks and a curious variation in the shape of the grips. He further contends that actual Walker parts were used in building these guns.

So what's wrong with all of these conclusions?

- Although it is well known that many Walker cylinders failed during proof tests, it can be shown that replacement cylinders were supplied and that every Walker passed its proof test prior to being accepted by the government. Colt would have no obligation to replace any guns or parts after acceptance. ^{2,3}
- There is absolutely no basis for either Fluck's assignment of serial numbers or his choosing the very precise quantity of 300 guns in this series. ⁴
- He also emphasized frame markings and the use of the tiny number stamps which were used on Walkers and are again seen in his "series." As we will see, it is exactly those markings and number stamps which disprove his theory.
- His contention that surplus Walker parts, such as trigger guards and backstraps, were used is not borne out of close inspection of specimen guns. Walker backstraps were made of steel; Dragoon straps in the early 2000's were strictly made of brass.

ASAC member G. Maxwell Longfield deserves most of the credit for setting the record straight. Along with David Basnett, he published a tract entitled "*Observations on Colt's Second Contract—November 2, 1847.*" In it he revealed that he collected data on more than a dozen Dragoons that exhib-

ited the "Fluck" characteristics and included "specimens from nearly every 100 pistols by serial number" ranging from the 2000s to the 2900s.

Longfield and Basnett conclude: "It appears to us, based on our research, that what Mr. Fluck really found were examples of the first (government) shipment of Dragoon pistols, not a hidden group of 300 replacements for the Walkers." ^c

I personally became interested when I acquired my own "Fluck" Dragoon. I was curious when I saw that the gun had all of the "Fluck" characteristics but that the serial number fell outside the "Fluck" range (#2193). I checked Flayderman's guide and although he does have a listing for what he calls "U.S. Walker Replacement Dragoon," he hedges a bit and mentions the Longfield/Basnett tract, noting that "the dozen or so specimens they observed are too small a number to draw definitive conclusions."

I started to make inquiries among other Colt enthusiasts and soon expanded the list to over two dozen specimens, including guns very close to both ends of the Longfield/Basnett "bracket" for Colt's Second Contract, i.e., serial numbers 2001 through 3000.

Subsequently, along with the late Paul Sorrell and the late Kenneth Moore, I published an article in *Gun Report* entitled "Debunking the Fluck Dragoon." The resulting feedback was amazing. I now have a register of approximately 120 serial numbers, certainly enough to draw definitive conclusions. ⁵

Among those guns ultimately recorded, bracketing the "inside range" were #2030 and #3000. Bracketing the "outside range" were #1921 and #3011, again supporting my conclusions.

The serial number stamps and frame markings tell an interesting story. In *Sam Colt's Own Record*, it is listed that among the leftover tooling moved from the Whitneyville Walker factory to Hartford were a set of number and letter stamps as well as a "COMPANY" stamp ^d These were clearly the stamps used to number the Walker pistols. The serial number stamps were distinctively tiny as can be seen in Figures 2 and 3.

These tiny serial number stamps were first used with the civilian Walkers, serial numbers 1001 to 1100, and continued for the Whitneyville Dragoons, serial numbers 1101 through approximately 1340. They appear again at serial number 2001 and were in further use until approximately serial number 2650, when it is presumed they wore out. A new, significantly larger set of numbers were used from that number forward. Also note that the newer, larger numbers bracketed the trigger guard screw while the tiny numbers were stamped below the screw. What is very significant about this observation is that serial numbers 1340 through 2000 show the larger bracketing numbers as do guns in the above-2700 range.

Frame stampings are equally significant and meaningful. Figure 4 shows the progression of frame stampings. The

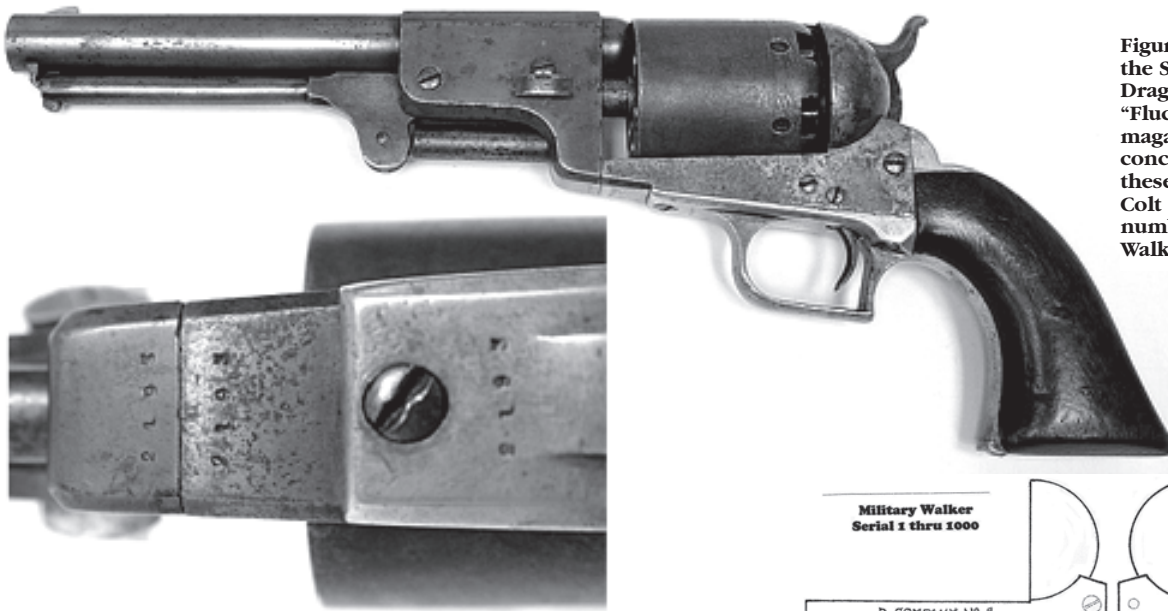
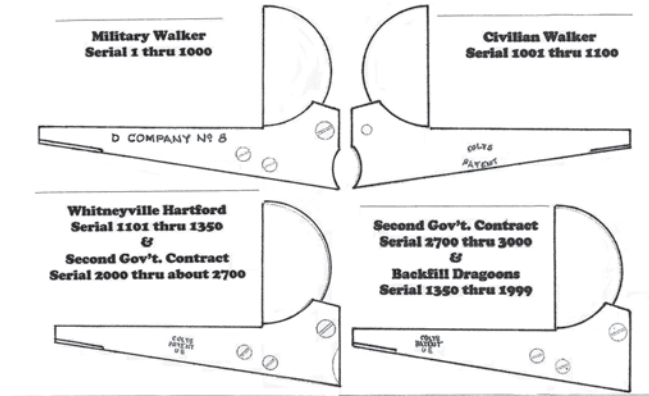

Figure 2. A typical example of the Second Government Contract Dragon. Known for years as the "Fluck Dragon" after a 1956 magazine article drew erroneous conclusions about the place these distinctive guns held in the Colt story. Note the tiny serial numbers, made with the leftover Walker number dies.



Frame Markings as Related to Serial Numbers

Figure 4. Similarly, the position and style of frame markings evolved, enabling the chronology of production to be precisely understood.

obvious conclusion is that Colt, for reasons of completeness perhaps, chose to number the guns made for the second government contract in a closed, out-of-sequence series, beginning with 2001 and continuing to 3000. That left him with a gap in his civilian production between 1340 and 2000 which he subsequently filled with later production guns.

Summarizing serial numbers by chronology:

First-	Military Walkers	1-1000
Second-	Civilian Walkers	1001-1100
Third-	Whitneyville Dragons	1101-1340 (about)
Fourth-	Second Govt. Contract	2001-3000
Fifth-	"Backfill" Dragons	1350-2000

In the past year two well respected national auction houses have offered "Fluck Dragons" in their catalogs. Only one has picked up on the true story of these guns. Colt legends die hard!

Chronology of Production

Year	Approximate Serial Range	Government Contracts	Military Quantity
1847	Walkers/1340	January 4, 1847	1000
1848	2001 to 3000	November 2, 1847	1000
1849	1340 to 2000	January 4, 1849	1000
1850	7000 to 9500	February 4, 1850	1000

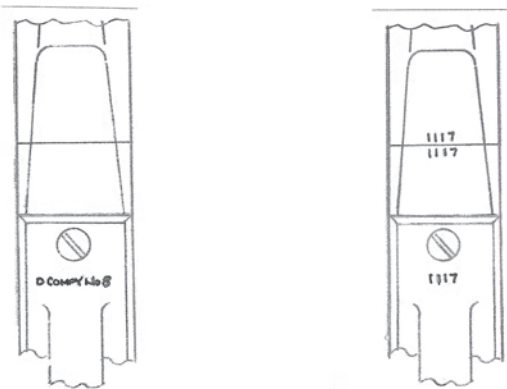

Military Walker 1 to 1000

Civilian Walker 1001 to 1100 and Early Hartford Dragons 1101 to 1350

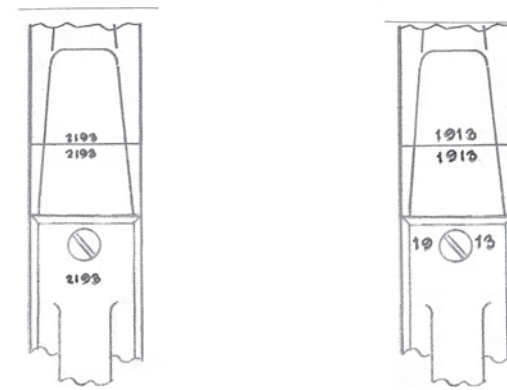

Second Govt. Contract 2000 to about 2700

Second Govt. Contract 2700 to 2999 and Backfill Dragons 1350 to 1999

Serial Number Placement as Related to Serial Number Range

Figure 3. The chronology of early Dragon production can be traced by examining the use and position of the serial numbers. The original Walker numbers were used until the dies wore out, at about serial 2700. They were replaced by larger dies and the position of the stamping was modified as shown.

1851	9500 to 10700	May 8, 1851	2000
1852	10700 to 12000	none	
1853	12000 to 13500	May 26, 1853	1000
	1 to 700	Hartford-London	
1854	13500 to 14000	none	
1855	14000 to 15500	January 15, 1855	1000

1856	15500 to 16200	various dates	330
1857	16200 to 16500	none	
1858	16500 to 18000	?	924
1859	18000 to 18500	?	108
1860	18500 to 19000	?	18
1861	19000 to 19800		

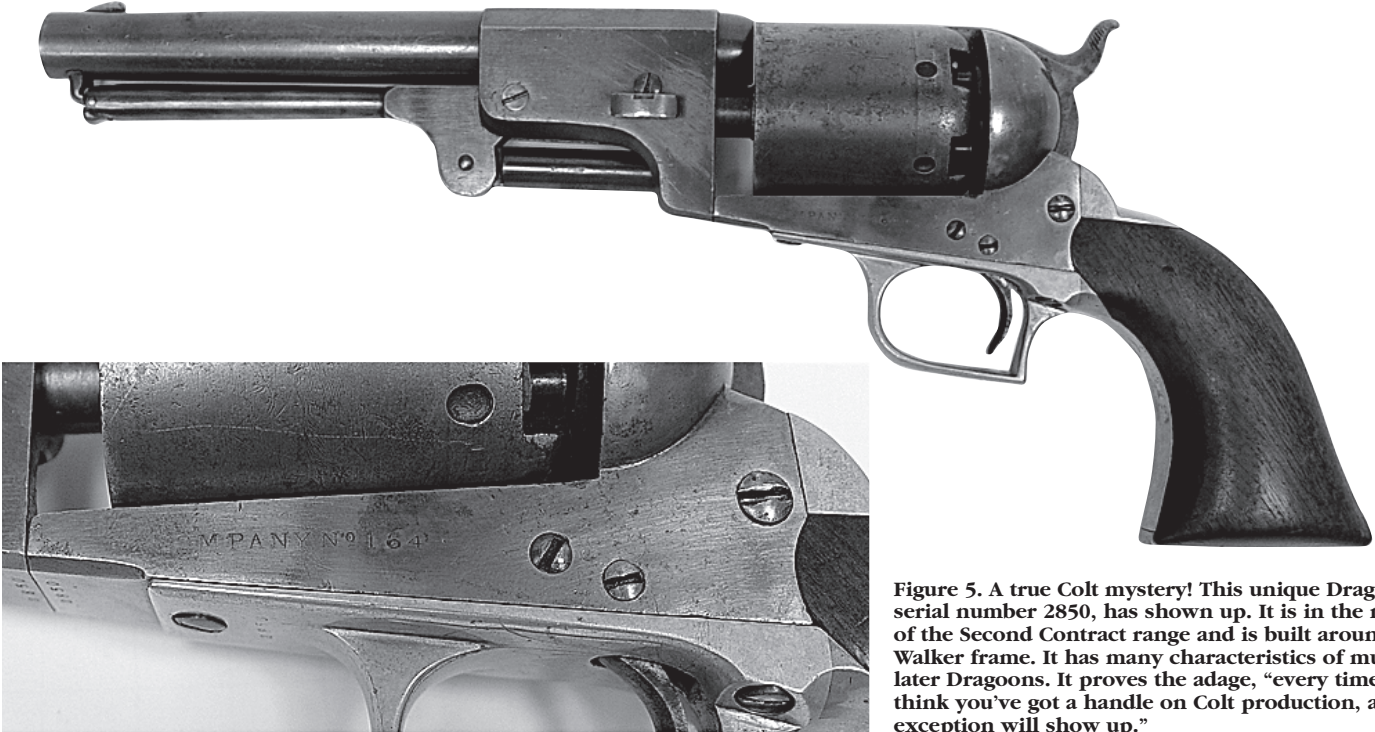

Figure 5. A true Colt mystery! This unique Dragoon, serial number 2850, has shown up. It is in the middle of the Second Contract range and is built around a Walker frame. It has many characteristics of much later Dragoons. It proves the adage, "every time you think you've got a handle on Colt production, an exception will show up."

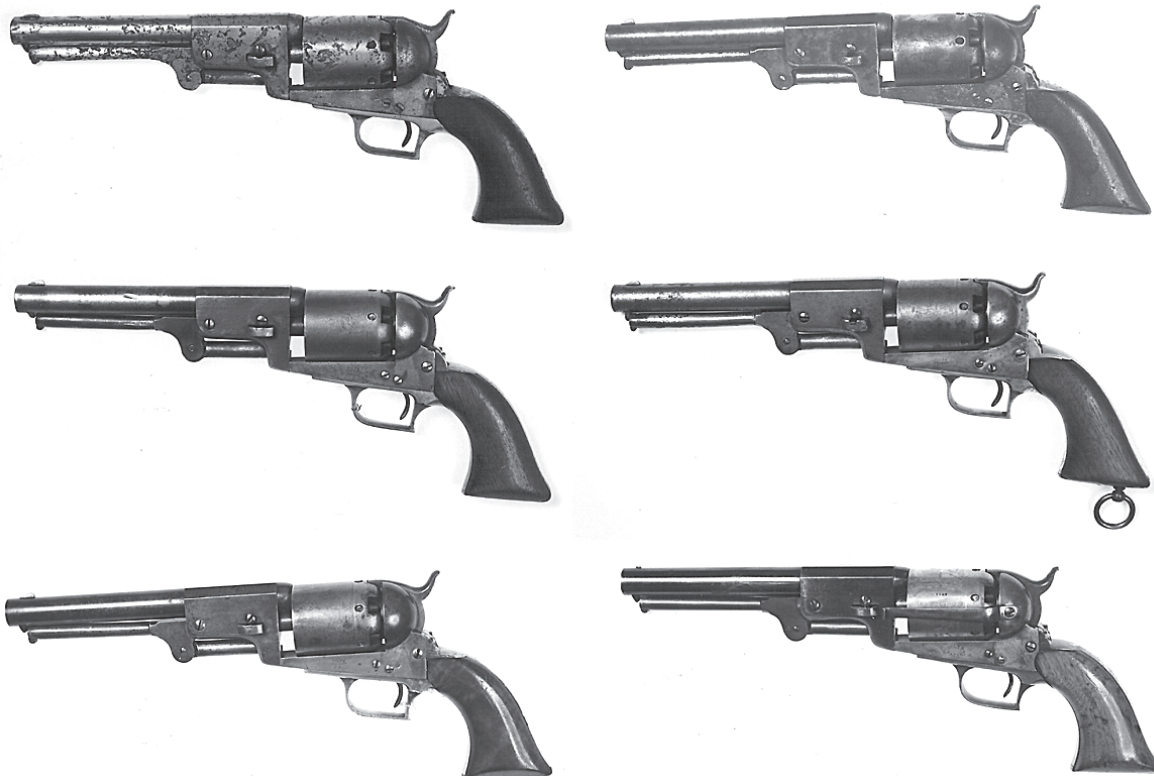

Figure 6. One of Fluck's contentions was that left-over Walker trigger guards and backstraps were used for what he termed "Walker Replacement Dragoons". He noted odd grip configurations in some of that series. In truth, the odd grip shapes came from distortions of standard trigger guards and backstraps as can be seen in this selection of earlier production Whitneyville Hartford guns—all of which are in the 1101 to 1340 serial range.

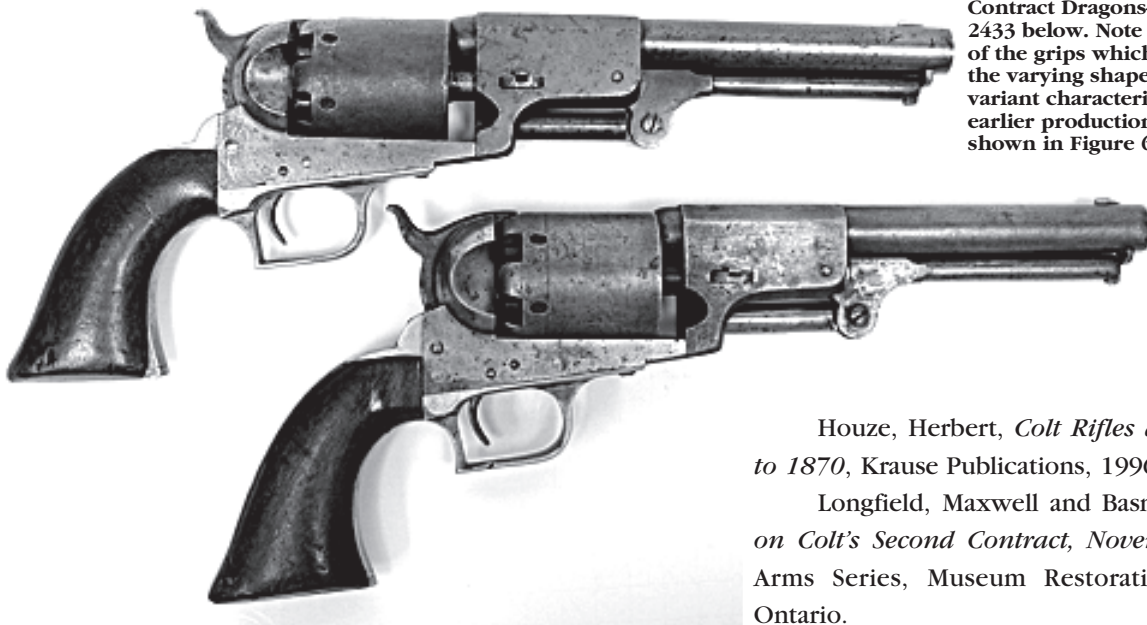

Figure 7. A pair of Second Government Contract Dragons—Serial 2193 above, serial 2433 below. Note the difference in the shape of the grips which were hand finished to suit the varying shapes of the backstraps. These variant characteristics can also be seen in the earlier production Whitneyville Dragoons shown in Figure 6.

NOTES

1. John Fluck passed away several months before his article was published and never got to see the collecting frenzy he started.

2. Walkers with cylinders which failed during testing can easily be identified by the lack of “Company” markings or serial numbers on their cylinders.

3. Military Walkers, contrary to general knowledge, actually did have serial numbers located on the back of their cylinders. Starting with C Company No. 1- serial 1 thru C Company No. 152-serial 152, etc. (Company C Walkers were the first manufactured, as Company C was Walker’s own Company.)

4. His assignment of numbers was apparently based upon extrapolation from observed specimens—no explanation is provided in the article.

5. Philip Boulton of the United Kingdom is a tireless documenter of Colt firearms—he was most useful in providing serial number listings, as were Robert Coelin and Dr. Will Noyes of the United States.

BIBLIOGRAPHY

- Colt, Sam, *Sam Colt's Own Record 1847*, Wolfe Publishing Company, Prescott, AZ.
 Flayderman, Norm, *Flayderman's Guide*, 8th Edition.
 Fluck, John, *Colt's Hartford Walker*, American Rifleman Magazine, September 1956.

Houze, Herbert, *Colt Rifles and Muskets, From 1847 to 1870*, Krause Publications, 1996.

Longfield, Maxwell and Basnett, David, *Observations on Colt's Second Contract, November 2, 1847*, Historical Arms Series, Museum Restoration Service, Bloomfield, Ontario.

Salzer, Dick, Sorrell, Paul and Moore, Kenneth, *Debunking the Fluck Myth*, Gun Report Magazine, May 2004.

Salzer, Dick, *Debunking the Fluck Myth—Follow-Up*, Gun Report Magazine, September 2004.

Salzer, Dick and Sorrell, Paul, *The Evolution of Colt's Dragoon Revolver*, Texas Gun Collector Magazine, Spring 2004.

Serven, James and Metzger, Carl, *Colt Dragoon Pistols*, Carl Metzger, Publisher, 1947.

Singer, Frank, *The Development of the Colt Dragoon Pistol*, The Rampant Colt Magazine, Part 1- Spring 1994, Part 2- Summer 1994, Part 3- Fall 1994.

Whittington, Lt. Col. Robert, *The Colt Whitneyville-Walker Pistol*, Brownlee Books, Hooks, TX, 1984.

ACKNOWLEDGEMENTS

- Philip Boulton
 Robert Coelin
 Dr. Will Noyes

REFERENCES

- a. *Colt Rifles and Muskets*, pgs. 26 thru 41
 b. *American Rifleman Magazine*, September 1956, page 34
 c. *Observations on Colt's Second Contract*, pg.27
 d. *Sam Colt's Own Record 1847*, pg. 123